

**DE SERIES TRAVERSE BEAM ROBOT  
WITH AC INVERTER OR SERVO MOTOR  
TRAVERSE (X-AXIS) DRIVE**

**Robots For Plastic Injection Molding Machines**

ISO 9001



ND: 12 100 15236 TMS

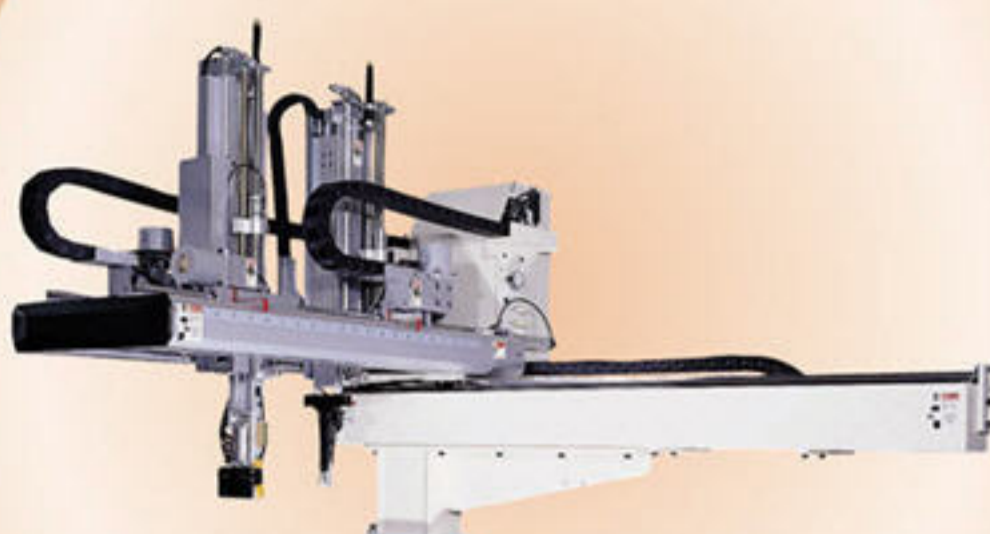

**DE(S) 1000 S W - 2R**

↑            ↑            ↑            ↑            ↑  
**1            2            3            4            5**

**1. MODEL**

- 1-1. DE WITH AC INVERTER MOTOR TRAVERSE DRIVE
- 1-2. DES WITH SERVO MOTOR TRAVERSE DRIVE

**2. VERTICAL STROKE**

- 2-1. 1000 mm
- 2-2. 1100 mm
- 2-3. 1200 mm

**3. CONFIGURATION**

- 3-1. S: SINGLE ARM
- 3-2. T: DOUBLE-ARM

**4. W: STANDARD LOW-HEIGHT TELESCOPIC ARM DESIGN**

**5. 2R: OPTIONAL REMOTE STROKE ADJUSTMENTS IN STRIP AND VERTICAL DIRECTIONS**

DE\_SPEC\_SHEET  
REV: B1, 200501

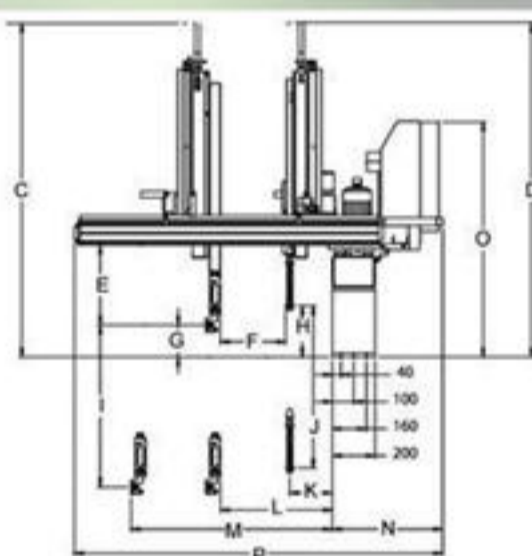
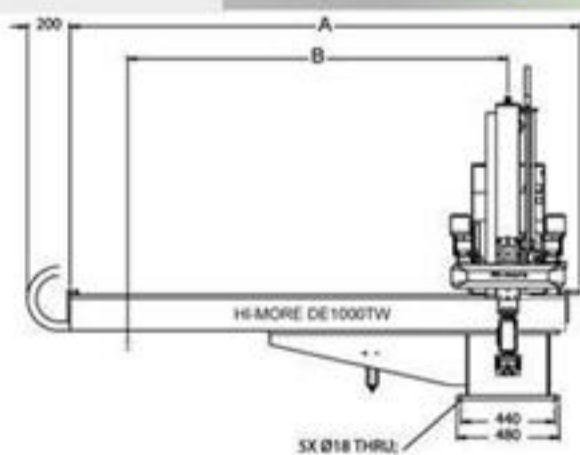

**INSTALLATION DIMENSIONS**

	A	B	C	D	E	F	G	H	I	J	K	L	M	N	O	P
DE1000	2500	2000	1565	1565	375	30	150	240	1000	1000	185	220	909	515	1105	1725
DE1100	2500	2000	1665	1615	375	30	150	240	1100	1100	185	220	909	515	1105	1725
DE1200	2500	2000	1765	1665	375	30	150	240	1200	1200	185	220	909	515	1105	1725

- Note:
1. All units are mm;
  2. F dimension is the minimum distance for double-arm configuration.
  3. L dimension is the minimum distance for single arm configuration .

**SPECIFICATIONS, PERFORMANCE AND UTILITY REQUIREMENTS**

MODEL		DE1000		DE1100		DE1200	
S: SINGLE ARM T: DOUBLE ARM		S	T	S	T	S	T
INJECTION MOLDING MACHINE SIZE (Ton)		350 ~ 450		450 ~ 550		550 ~ 650	
MAIN ARM	VERTICAL STROKE (mm)	1000		1100		1200	
	STRIP STROKE (mm)	400		400		400	
SUB-ARM	VERTICAL STROKE (mm)	1000		1100		1200	
	STRIP STROKE (mm)	300		300		300	
STANDARD TRAVERSE STROKE (mm)		2000					
WRIST FLIP ANGLE (°)		90°					
MINIMUM TAKE-OUT TIME (sec)		2.5		2.9		3.3	
MINIMUM TOTAL CYCLE TIME (sec) OF DE		12.0		12.4		12.8	
MINIMUM TOTAL CYCLE TIME (sec) OF DES		9.0		9.4		9.8	
AIR CONSUMPTION (NL/cycle)		60	75	70	85	80	95
SUGGESTED OPERATION AIR PRESSURE (Kgf/cm <sup>2</sup> )		5.5					
MAXIMUM ALLOWABLE AIR PRESSURE (Kgf/cm <sup>2</sup> )		9					
MAXIMUM PAYLOAD (Kg)		8					
INSTALLED WEIGHT (Kg)		260	300	275	325	290	350
POWER SUPPLY		3-PHASE, 220 VAC, 50/60HZ					

**HSM CONTROL SYSTEM**

1. EUROMAP / SPI COMPATIBLE INTERFACE
2. STANDARD ONE PRESSURE AND ONE VACUUM CIRCUITS; OPTIONAL CIRCUITS AVAILABLE, UP TO OVERALL SIX PRESSURE / VACUUM CIRCUITS
3. PROGRAMMABLE SIX SPARE INPUTS AND SIX SPARE OUTPUTS FOR APPLICATIONS OF EOAT, CONVEYOR, NIPPER, MOLD RELEASE SPRAY, DOWNSTREAM EQUIPMENTS, ETC.
4. STANDARD CONVEYOR INDEXING AND PALLETIZING FEATURES